

MATERIAL SPECIFICATIONS:

Body & Housing: PA, UL-94V-HB / UL-94V-0 rated, color black

Contacts: Bronze, Gold plated

MECHANICAL SPECIFICATIONS:

Contacts: 8

Durability: >5000 mating cycles.

Cable Diameter: 2.5 - 8mm

Wire gauge: 24AWG max.

ELECTRICAL SPECIFICATIONS:

Rated current: 2A per contact

Rated voltage: 175V

Contact resistance: <15 mohms

Rated impulse voltage: 1750V

IEC/UL 61010-1 SPECIFICATIONS:

Material group: I, II

Overload category: II

Pollution degree: 2

ENVIRONMENTAL SPECIFICATIONS:

Degree of Protection: IP67 unmated and mated

Operating Temperature: -25°C ~ +85°C

RoHS
COMPLIANT

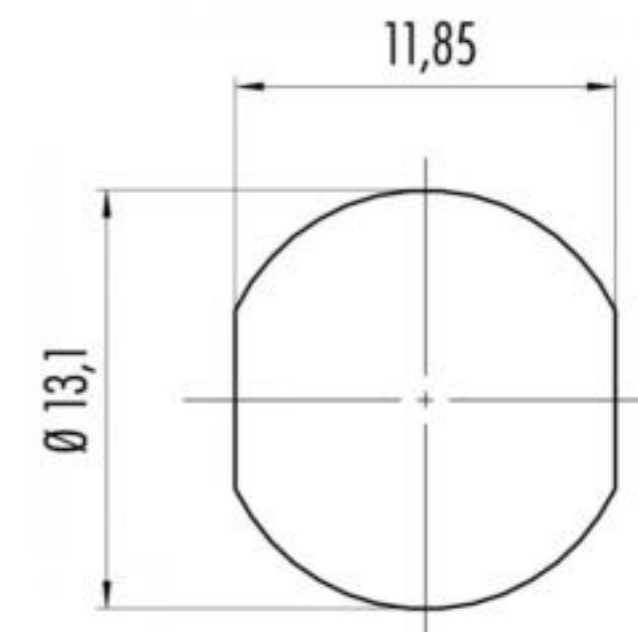

PANEL CUTOUT

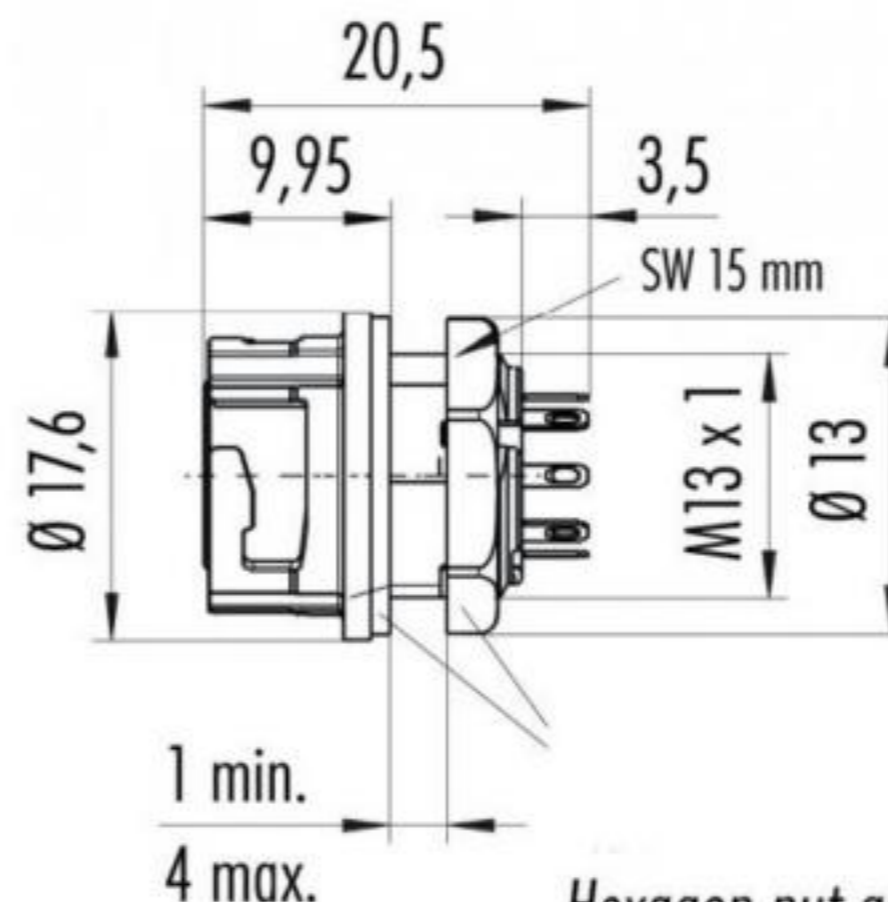

Hexagon nut and
flat seal enclosed loose

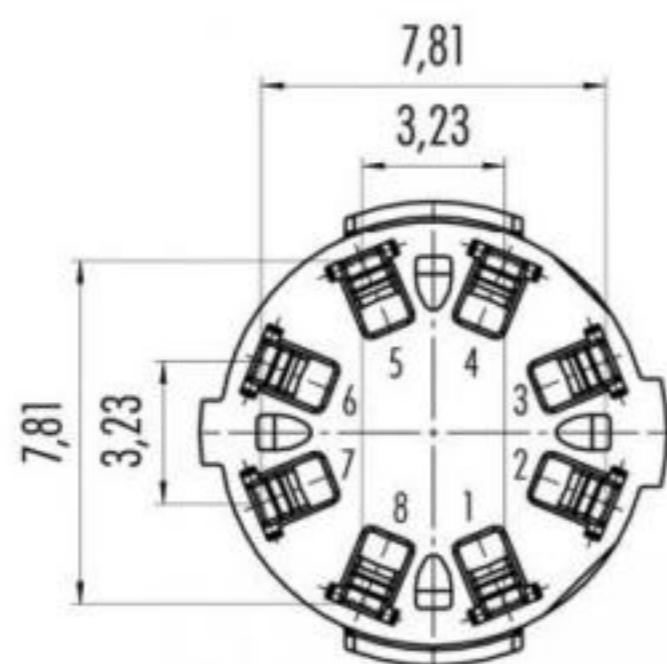

	X	Y
1	1,62	-3,90
2	3,90	-1,62
3	3,90	1,62
4	1,62	3,90
5	-1,62	3,90
6	-3,90	1,62
7	-3,90	-1,62
8	-1,62	-3,90

TOLERANCE UNLESS OTHERWISE SPECIFIED	
X	± 1
X.X	± 0.4
X.XX	± 0.13

DRAWN BY	PB	DATE:	10/29/14
CHECK BY		DATE:	
APPR BY		DATE:	

Power Dynamics, Inc.

Phone: 973 560-0019 Whippany, New Jersey Fax: 973 560-0076

PART: HARSH ENVIRONMENT CONNECTOR
SERIES 2 FEMALE PANEL MOUNT; SOLDER PINS

PART #	PD-HEC2-FPC-S	SHEET	1 of 1
SIZE:	A	ALL DIMENSIONS FOR REFERENCE ONLY	REV:
SCALE:	NTS	DIMENSIONS ARE IN MILLIMETERS	

REVISIONS	CHNG	CHK	APPR
CHANGE			
DATE			
REV			